



*An Online PDH Course
brought to you by
CEDengineering.com*

An Introduction to Petroleum Fuel Facilities: *Atmospheric Storage Tanks*

Course No: P04-002

Credit: 4 PDH

J. Paul Guyer, P.E., R.A., Fellow ASCE, Fellow AEI



Continuing Education and Development, Inc.

P: (877) 322-5800

info@cedengineering.com

www.cedengineering.com

This course is adapted from the Unified Facilities Criteria of the United States government, which is in the public domain, has unlimited distribution and is not copyrighted.

CONTENTS

1. INTRODUCTION
2. GENERAL REQUIREMENTS
3. GENERAL CRITERIA
4. HORIZONTAL ABOVEGROUND TANKS (SINGLE-WALL STEEL)
5. HORIZONTAL ABOVEGROUND TANKS (DOUBLE-WALL STEEL)
6. HORIZONTAL ABOVEGROUND TANKS (FIRE-RESISTANT)
7. HORIZONTAL ABOVEGROUND TANKS (PROTECTED TANKS)
8. ABOVEGROUND VERTICAL STORAGE TANKS
9. UNDERGROUND HORIZONTAL STORAGE TANKS
10. UNDERGROUND VERTICAL STORAGE TANKS (CUT AND COVER)
11. APPURTENANCES
12. HEATERS
13. UNDERGROUND STORAGE TANK SPILL CONTAINMENT SYSTEMS
14. ABOVEGROUND TANK SPILL CONTAINMENT SYSTEMS
15. MISCELLANEOUS USE TANKS
16. SHIPBOARD OFF-LOAD FUEL STORAGE TANKS

1. INTRODUCTION. This discussion provides guidance for the design of bulk storage tanks, operating storage tanks, ground vehicle fueling tanks, miscellaneous use tanks, product recovery system tanks, contaminated fuel storage tanks, and jet engine test cell fuel storage tanks. Design guidance on issues related to storage tanks such as protection, location, coatings, product recovery, and spill containment systems are also covered in this chapter. This chapter generally applies to new tanks.

2. GENERAL REQUIREMENTS. Do not start design of any fueling system without first becoming completely familiar with General Design Requirements.

3. GENERAL CRITERIA. Design liquid fuel storage tanks to comply with the operational requirements of the particular command having jurisdiction of the facility. Ensure that the design is appropriate for the mission of the facility. Consider the operational requirements of the users of the fuel.

3.1 MATERIALS. All aboveground storage tanks shall be constructed of steel or concrete encased steel.

3.2 PROTECTION. Provide protection to preserve product quality and ensure minimal losses by evaporation, dilution, leakage, substitution, theft, contamination, attack, sabotage, fire, and damage to the environment. Use aboveground steel tanks unless the mission of the facility or other practical considerations dictate that underground tanks be used. Cut and cover (buried vertical) tanks are not normally used in the continental United States. Cut and cover tanks may be required if the dispensing system is located in clear zones or explosive cordon areas. Conduct economic, operational, and mechanical analyses of remotely locating the pump house/system from the hydrant system versus constructing cut and cover tanks. For tanks located in areas subject to flooding, design in accordance with NFPA 30.

3.3 DESIGN REQUIREMENTS. Fuel storage facilities provide an operating and reserve supply of fuel. The types and sizes of storage tanks depend on safety, economics, terrorist

activity, locality, and intended service. Provide separate storage for each type and grade of fuel. For aviation activities, provide a minimum of two tanks for each type of fuel.

3.4 STORAGE CAPACITY. The capacity or size of each fuel storage tank is based upon the logistical and mission requirements for the facility and any other facility to be supported from it. For a stated volume of each fuel, fewer tanks of larger size will result in maximum economy. The appropriate Owner approval will determine the number and size of tanks required. Provide a minimum of two tanks at aviation activities for each type of aviation turbine fuel to receive and isolate new receipts until tested and checked for quality and quantity while the facility continues to function with stocks on hand. In general, capacities of individual tanks should not exceed 50 percent of the total storage volume required for each type and grade of fuel. Do not provide tanks with capacities greater than 100,000 barrels (16,000,000 L) except when larger tanks are specifically authorized by the Owner.

3.5 TANK SPACING.

3.5.1 VERTICAL TANKS. Provide a minimum distance between the shells of vertical tanks, both aboveground and underground, of not less than one diameter of the larger tank.

3.5.2 HORIZONTAL UNDERGROUND TANKS. Provide a minimum clearance between shells of adjacent horizontal underground tanks of 3 feet (0.9 m).

3.5.3 HORIZONTAL ABOVEGROUND TANKS (SINGLE-WALL AND DOUBLE-WALL STEEL) (NON-FIRE RESISTANT AND NON-PROTECTED). Provide a minimum clearance between aboveground horizontal tanks with capacities 50,000 gallons (189,300 L) or under as follows:

a) Arrange tanks in pairs with a minimum of 5 feet (1.5 m) between tanks in each pair and 10 feet (3 m) between adjacent tanks of two pairs in the same row.

- b) Space adjacent groups of more than two pairs in a single row with at least 20 feet (6 m) between the nearest tanks of the groups.
- c) Provide a minimum end-to-end spacing between tanks in longitudinal rows of 20 feet (6 m).
- d) Provide a UL nameplate on tanks stating that the tanks are approved for that material and service.
- e) In addition to requirements listed in this paragraph, tanks located in facilities governed by NFPA 30A, such as marine/motor fuel dispensing facilities, shall comply with NFPA 30A.

3.5.4 HORIZONTAL ABOVEGROUND TANKS (FIRE RESISTANT). Provide minimum clearance and spacing between fire resistant, secondarily contained aboveground horizontal tanks in compliance with NFPA 30 and NFPA 30A as applicable.

3.5.5 HORIZONTAL ABOVEGROUND TANKS (PROTECTED). Provide minimum clearance and spacing between protected, secondarily contained aboveground horizontal tanks in compliance with NFPA 30 and NFPA 30A as applicable.

3.6 DISTANCE FROM BUILDINGS AND PROPERTY LINES. Locate tanks a sufficient distance from buildings and property lines to prevent the ignition of vapors from the tank and to protect buildings and their occupants or contents from damage by a tank fire. Assume that the maximum internal pressure in a fire exposure will not exceed 2.5 psig (17 kPa). As a minimum, comply with requirements of the following paragraphs.

3.6.1 UNDERGROUND TANKS. Locate underground tanks with respect to buildings or similar structures so that the soil pressure created by the building foundations will not be transmitted to the tank. Pumping facilities, often located directly above underground tanks, are accepted. Locate horizontal cylindrical tanks less than or equal to 12 feet (3.7

m) in diameter not less than 10 feet (3 m) from the nearest point of an adjacent building or property line. Locate vertical underground tanks at least 25 feet (7.6 m) from the nearest point of an adjacent building and 50 feet (15 m) from the nearest property line.

3.6.2 ABOVEGROUND TANKS. Locate aboveground tanks with consideration of fire safety. The first consideration is to prevent the ignition of vapors from the tank, and the second consideration is to protect the building and its occupants or contents from damage by a tank fire. As a protective measure, provide all aboveground tanks with some form of emergency relief venting for fire exposure in accordance with NFPA 30. In the following, it is assumed that all tanks are constructed or equipped so that the maximum internal pressure in a fire exposure will not exceed 2.5 psi (17 kPa). Required minimum distances for aboveground tanks from buildings and property lines are as follows:

a) Tanks, all sizes and types, not protected or fire-resistant, containing petroleum fuels with a flash point less than 100 degrees F (38 degrees C), 100 feet (30 m) or one tank diameter, whichever is greater, with the exception that tanks located in facilities governed by NFPA 30A, such as marine/motor fuel dispensing facilities, shall comply with NFPA 30A criteria.

b) Tanks, not protected or fire-resistant, containing petroleum fuels with a flash point of 100 degrees F (38 degrees C) or greater in accordance with Table 1 below:

Tank Capacity gallons (L)	Minimum Distance from Nearest Property Line Feet (m)	Minimum Distance from Nearest Building Feet (m)
275 or less (1040 or less)	10 (3.0)	5 (1.5)
276 to 750 (1041 to 2800)	20 (6.0)	10 (3.0)
751 to 12,000 (2801 to 45 400)	30 (10)	15 (4.5)
12,001 to 30,000 (45 401 to 113 500)	40 (12)	20 (6.0)
30,001 to 50,000 (113 501 to 189 000)	60 (18)	60 (18)
50,001 to more (189 001 or more)	100 (30)	100 (30)

Table 1

Minimum distances of tanks from adjacent buildings or property lines

c) For aboveground, fire-resistant tanks in facilities governed by NFPA 30A, use NFPA 30A guidelines.

d) For aboveground, protected tanks, use NFPA 30 guidelines. Protected tanks located in facilities governed by NFPA 30A, such as marine/motor fuel dispensing facilities, shall comply with NFPA 30A \1\ criteria /1/.

3.7 DISTANCE FROM ROADWAY, RAILROADS AND POWER LINES. For tanks located in facilities governed by NFPA 30A, use NFPA 30A guidelines.. For all other storage tanks, the minimum distances from adjacent roadways, railways, railroads, and overhead electric power lines are as follows:

3.7.1 UNDERGROUND TANKS. Spacing and clearances for underground tanks shall be:

a) A minimum of 25 feet (7.6 m) from regularly traveled roads and highways, not including tank farm utility and fire access roads.

b) 25 feet (7.6 m) from railroad spur tracks not used for through traffic.

c) No less than 100 feet (30 m) from main railroad tracks carrying through traffic.

d) 50 feet (15 m) from overhead electric power transmission and distribution wires.

3.7.2 ABOVEGROUND TANKS.

a) The greater of 100 feet (30 m) or one tank diameter from regularly traveled roads and highways, not including tank farm utility and fire access roads.

b) 50 feet (15 m) from railroad spur tracks not used for through traffic.

c) 200 feet (60 m) from main railroad tracks carrying through traffic.

d) 50 feet (15 m) from overhead electric power transmission and distribution wires.

3.8 DISTANCE FROM TANK TRUCK AND TANK CAR OFF-LOADING AND LOADING FACILITIES. For tanks located in facilities governed by NFPA 30A, use NFPA 30A guidelines. For fire resistant or protected horizontal aboveground tanks and underground tanks, provide a minimum separation of 25 feet (7.6 m) from tank truck and tank car off-loading and loading facilities. For all other tanks, provide a minimum separation of 50 feet (15 m) from tank truck and tank car off-loading and loading facilities.

3.9 INTERIOR COATINGS. To extend the life of steel storage tanks, coat new tanks according to the following guidelines:

a) Vertical tanks

- All aviation, diesel fuel marine (F-76), additive, and lube oil tank. Interiors shall be 100 percent coated, including floor, shell, and underside of the roof.
- Other products. Coat the floor, the underside of the fixed roof, and the bottom 40 inches (1000 mm) of the tank shell. Additional coating of up to 100 percent requires economic justification and The Owner approval. \1\ Tanks containing E85 are not to be coated internally unless otherwise approved by The Owner.

b) Horizontal tanks

- For all products, tank interiors shall be 100 percent coated. Tanks containing E85 are not to be coated internally unless otherwise approved by The Owner.

c) For all products coat the interior and exterior of carbon steel piping located inside the tank, and steel appurtenances inside all tanks. Carbon steel piping, and steel appurtenances located inside of tanks containing E85 are not to be coated internally unless otherwise approved by The Owner.

3.10 EXTERIOR COATINGS.

a) Protect the exterior surface of all aboveground steel tanks by coating in accordance with appropriate guide specifications.

- b) Protect the exterior surfaces of all underground horizontal steel tanks with a factory-applied coating specified in the appropriate guide specifications.
- c) For protected tanks, with exterior steel containment, consider exterior fiberglass cladding for extremely corrosive atmospheres or seaside locations.

3.11 FILL PIPING. Size the pipe so that the velocity does not exceed 12 feet (3.7 m) per second at maximum flow rate. Provide a means for reducing the velocity of flow to 3 feet (0.9 m) per second until the filling inlet nozzle is completely submerged and/or the floating pan has lifted off its legs.

3.12 VAPOR EMISSION CONTROL SYSTEMS. Provide a vapor emission control system for tanks that store products having a true vapor pressure of 0.75 psia (5 kPa) or more located in air pollution control areas in which the discharge of petroleum vapors is controlled or prohibited. Ensure that the system has sufficient capacity to control the vapor discharged from the tank vents at maximum filling rate in conformance with local air quality regulations. If gasoline is being handled, provide, as a minimum, Stage I vapor recovery and the piping for Stage II. If not required by local or state regulations at time of construction, connect the Stage II piping to the tank and cap it at the dispenser.

3.13 STRAPPING TABLES.

Provide two API MPMS Chapter 2 strapping tables for all tanks greater than 5,000 gallons (19,000 L). Provide one of the tables in U.S. Customary units reading in 1/16-inch increments, gallons and barrels and one in metric units reading in 2mm increments, liters and cubic meters. Provide electronic media data files. Determine strapping table volumes for tanks of 5,000gallons (19,000 L) and larger using physical measurements, not calculated values. The tables are to be calibrated for critical measurement and certified by a Professional Engineer. For tanks less than 5,000 gallons (19,000 L), provide strapping table certified by the tank manufacturer that reads 1/16-inch (2mm) increments in gallons (liters).

3.14 PRODUCT RECOVERY SYSTEMS

3.14.1 GENERAL DESIGN CONSIDERATIONS. Provide pumps, piping, valves, and tanks to collect and store usable aviation turbine fuel which would otherwise become waste from operational or maintenance activities. Consider a product recovery system for other products. Include a tank to collect fuel/water mixtures from tank and equipment sumps, equipment drains, product saver tanks, high point vents, low point drains, and any other equipment from which fuel/water mixtures can be collected. Separate the fuel and water portions. Filter the fuel portion and return to operating storage tanks. Do not discharge the water portion to surface water without additional treatment and permits or treat the water portion as wastewater. Refer to DoD Standard Design AW 78-24-28. These systems are standard with the hydrant and aircraft direct fueling systems.

3.14.2 PRODUCT RECOVERY TANKS. For hydrant and aircraft direct fueling systems provide the tank directed by the Owner. For other systems, provide a tank with, at a minimum, the following appurtenances:

- a) Level gauge.
- b) Overfill protection level control valve.
- c) High and low level switches with alarms and controls.
- d) A motor driven fuel transfer pump that returns recovered fuel back to the system through a hard piped connection.
- e) A motor driven sump pump for emptying the tank.
- f) Manual gauging hatch.
- g) Vent.
- h) ATG system for aboveground product recovery tanks having a capacity more than or equal to 4,000 gallons (15,000 L).
- i) Do not allow sight flow indicators to be installed on product recovery tanks.

3.14.3 VERTICAL STORAGE TANKS. In addition to the product recovery tank(s) for the facility, all vertical storage tanks storing aviation turbine fuel should include a product

saver tank with electric pump, unless the tank is equipped with a filter/separator to remove water from the sump. A product saver tank is a small aboveground tank piped and valved to allow drawing water from the bottom of the storage tank and returning the product after the water has been separated and disposed of in accordance with environmental regulations.

3.15 REGISTRATION. Register all tanks with the appropriate state and local agencies as required. All tanks shall have a nameplate installed in accordance with API Std 650.

4. HORIZONTAL ABOVEGROUND TANKS (SINGLE-WALL STEEL)

4.1 GENERAL DESIGN CONSIDERATIONS. If small factory-built aboveground storage tanks are required, use horizontal tanks. Limit tank diameter to 12 feet (3.7 m) or less and capacity to 50,000 gallon (191,000 L) or less. Require tank to be of welded steel construction in accordance with UL 142. Plastic and/or fiberglass aboveground storage tanks are not allowed. Requirements for all horizontal aboveground storage tanks shall comply with NFPA 30 Chapter 22 Aboveground Storage Tanks. Tanks located in facilities governed by NFPA 30A, such as marine/motor fuel dispensing facilities, shall comply with NFPA 30A.

4.2 TANK DESIGN REQUIREMENTS.

- a) Install the tank so that the bottom slopes downward toward one end at a slope of 1 percent. Locate transfer pumps or suction piping at the high end of the tank; locate water drawoff at low end of the tank.

- b) Provide water drawoff lines in each tank. For aviation fueling systems, arrange piping so that the fuel in the tanks may be recirculated through the filter/separators.

- c) Provide steel tanks with steel saddles or skids in accordance with UL 142. The bottom of tank is to be no more than 12 inches (300 mm) above grade to avoid the need for fireproofing. Mount steel supports on a reinforced concrete foundation.

- d) Tanks shall be inspected in accordance with STI SP001 by a STI certified inspector prior to commissioning.

5. HORIZONTAL ABOVEGROUND TANKS (DOUBLE-WALL STEEL)

5.1 GENERAL DESIGN CONSIDERATIONS. Limit tank diameter to 12 feet (3.7 m) or less and capacity to 50,000 gallon (191,000 L) or less. Require tank to be of welded steel construction in accordance with UL 142. No fiberglass aboveground storage tanks are allowed. The main advantage of double-wall steel storage tanks over single-wall steel storage tanks is that separate spill containment may not be required. Secondary containment-type tanks can be used to provide spill control per NFPA 30, if the capacity of the tank is no more than 12,000 gallons (45,400 L). The tank size may be increased to 20,000 gallons (75,700 L) if Class II or III liquids are used. All of the criteria in the NFPA regulations for the appropriate application must be met before a secondary containment-type tank is used without separate spill containment. Requirements for double-wall steel horizontal aboveground storage tanks shall comply with NFPA 30, the chapter entitled, “Aboveground Storage Tanks”. Tanks located in facilities governed by NFPA 30A, such as marine/motor fuel dispensing facilities, shall comply with NFPA 30A.

5.2 TANK DESIGN REQUIREMENTS.

- a) For flammable liquid installations, require additional curbing containment based on tank filling rates if there is a chance of a fuel spill entering a critical area.

- b) Install the tank so that the bottom slopes downward toward one end at a slope of 1 percent. Locate transfer pumps or suction piping at the high end of the tank; locate water drawoff at low end of the tank.

- c) Provide water drawoff lines in each tank. For aviation fueling systems, arrange piping so that the fuel in the tanks may be recirculated through the filter/separators.

- d) Provide protective bollards for tanks not surrounded by a dike. Bollards shall not be less than 4 feet (1.2 m) high and 4-inches (100 mm) in diameter, of steel construction, filled with concrete, and spaced not less than 4 feet (1.2 m) on center.

- e) Provide steel tanks with steel saddles or skids in accordance with UL 142. The bottom of tank is to be no more than 12 inches (300 mm) above grade to avoid the need for fireproofing. Mount steel supports on a reinforced concrete foundation. Mount rectangular (flat bottomed) tanks of 4,000 gallons (15,100 L) or greater 12 inches (300 mm) above grade to allow inspection and maintenance of the tank bottom.

- f) Require the tank to be pressure-tested after installation.

- g) Tanks shall be inspected in accordance with STI SP001 by a STI certified inspector prior to commissioning.

- h) A primary tank constructed of stainless steel is permitted when required.

- i) Require support channels with anchor holes for earthquake/hurricane/flood restraint tie down.

- j) Require steel to be a minimum thickness of 3/16-inch (5 mm) for interior carbon steel tank.

6. HORIZONTAL ABOVEGROUND TANKS (FIRE-RESISTANT)

6.1 GENERAL DESIGN CONSIDERATIONS. When small (250 to 20,000 gallon (900 to 75,000 L) capacity) aboveground storage tanks are required and there are clearance or fire exposure problems and the additional cost can be justified, consider the use of fire-resistant storage tanks. The main advantage of fire-resistant tanks over the single wall steel tanks is that separate spill containment may not be required and the vault system provides an added measure of fire protection. Secondary containment-type tanks can be used to provide spill control per NFPA 30, if the capacity of the tank is no more than 12,000 gallons (45,400 L). The tank size may be increased to 20,000 gallons (75,700 L) if Class II or III liquids are used. All of the criteria in the NFPA regulations for the appropriate application must be met before a secondary containment-type tank is used without separate spill containment. Require tanks to be factory-constructed with a UL 142 welded steel primary tank. Tanks may be used in applications where, in addition to the above considerations, construction of a separate spill containment system for secondary containment purposes would have a negative impact on operations and/or aesthetics. Tanks located close to buildings or with integral fuel dispensers must be UL-listed secondary containment tanks, utilizing steel inner and outer tanks that can provide interstitial containment which is both pressure testable and verifiable. Such tanks usually have a fill of regular or insulating concrete. Ensure the two-hour fire rating meets or exceeds all requirements of NFPA 30A for “fire resistance” tanks, and provides a minimum two-hour fire rating in accordance with 2080.

6.2 TANK DESIGN REQUIREMENTS.

a) For flammable liquid installations, require additional curbing containment based on tank filling rates if there is a chance of a fuel spill entering a critical area.

b) Install the tank so that the bottom slopes downward toward one end at a slope of 1 percent. Locate transfer pumps or suction piping at the high end of the tank; locate water drawoff at low end of the tank.

- c) Provide water drawoff lines in each tank. For aviation fueling systems, arrange piping so that the fuel in the tanks may be recirculated through the filter/separators.

- d) A primary tank constructed of stainless steel is permitted when required.

- e) Require support channels with anchor holes for earthquake/hurricane/flood restraint tie down.

- f) Require steel to be a minimum thickness of 3/16-inch (5 mm) for the interior carbon steel tank.

- g) Mount rectangular (flat bottomed) tanks of 4,000 gallons (15,100 L) or greater 12 inches (300 mm) above grade to allow inspection and maintenance of the tank bottom.

- h) Provide protective bollards in traffic areas. Bollards shall be not less than 4 feet (1.2 m) high and 4-inches (100 mm) in diameter, of steel construction, filled with concrete and spaced not less than 4 feet (1.2 m) on center.

- i) Require the tank to be pressure-tested after installation.

- j) Tanks shall be inspected in accordance with STI SP001 by a STI certified inspector prior to commissioning.

7. HORIZONTAL ABOVEGROUND TANKS (PROTECTED TANKS)

7.1 GENERAL DESIGN CONSIDERATIONS. When small (250 to 20,000 gallon (900 to 75,000 L) capacity) aboveground storage tanks are required and there are clearance or fire exposure problems and the additional cost can be justified, consider the use of protected storage tanks. The main advantages of protected tanks over the single wall steel tanks are that a separate dike (containment) may not be required and the vault system provides an added measure of fire protection. Secondary containment-type tanks can be used to provide spill control per NFPA 30, if the capacity of the tank is no more than 12,000 gallons (45,400 L). The tank size may be increased to 20,000 gallons (75,700 L) if Class II or III liquids are used. All of the criteria in the NFPA regulations for the appropriate application must be met before a secondary containment-type tank is used without separate spill containment. Additional benefits include added protection from ballistic and vehicular impact and reduced evaporation of volatile fuels in warm climates. Require tanks to be factory-constructed with a UL 142 welded steel primary tank. Tanks may be used in applications where, in addition to the above considerations, construction of a separate dike for secondary containment purposes would have a negative impact on operations and/or aesthetics. Tanks located close to buildings or with integral fuel dispensers must be UL-listed secondary containment tanks, utilizing steel inner and outer tanks that can provide interstitial containment which is both pressure testable and verifiable. Such tanks usually have a fill of regular or insulating concrete. Ensure the two-hour fire rating meets or exceeds all requirements of NFPA 30A for “fire resistance” tanks, and provides a minimum two-hour fire rating in accordance with UL 2085.

7.2 TANK DESIGN REQUIREMENTS.

- a) For flammable liquid installations, require additional curbing containment based on tank filling rates if there is a chance of a fuel spill entering a critical area.

- b) Install the tank so that the bottom slopes downward toward one end at a slope of 1 percent. Locate transfer pumps or suction piping at the high end of the tank; locate water draw-off at low end of the tank.

- c) Provide water drawoff lines in each tank. For aviation fueling systems, arrange piping so that the fuel in the tanks may be recirculated through the filter/separators. Locate the water drawoff piping at the low end of the tank.

- d) For applications not requiring secondary containment, such as residential heating oil tanks where aesthetics may be the prime concern, consider protected, exposed aggregate, tanks with a UL 2085 secondary containment protected rating without the outer steel jacket.

- e) A primary tank constructed of stainless steel is permitted when required.

- f) Require support channels with anchor holes for earthquake/hurricane/flood restraint tie down.

- g) Require steel to be a minimum thickness of 3/16-inch (5 mm) for the interior carbon steel tank.

- h) Mount rectangular (flat bottomed) tanks of 4,000 gallons (15,100 L) or greater 12 inches (300 mm) above grade to allow inspection and maintenance of the tank bottom.

- i) Provide protective bollards in traffic areas. Bollards shall be not less than 4 feet (1.2 m) high and 4-inches (100 mm) in diameter, of steel construction, filled with concrete, and spaced not less than 4 feet (1.2 m) on center.

- j) Require the tank to be pressure-tested after installation.

- k) Tanks shall be inspected in accordance with STI SP001 by a STI certified inspector prior to commissioning.

8. ABOVEGROUND VERTICAL STORAGE TANKS

8.1 GENERAL DESIGN CONSIDERATIONS. Provide cylindrical single-wall steel aboveground vertical storage tanks meeting one of the following criteria (as approved by The Owner):

a) Factory-fabricated tanks complying with UL 142 criteria. The diameter of the tanks is limited by transportation restrictions. Although these tanks are fabricated in sizes up to 50,000 gallon (191,000 L), they become quite tall due to the diameter limitation. Give special consideration to height/diameter ratio to ensure tank stability.

b) Field-erected tanks not requiring an internal pan comply with DoD Standard Design AW 78-24-27. The standard design includes tanks ranging in capacity from 5,000 barrels (800,000 L) through 100,000 barrels (16,000,000 L). Requires following design considerations for tanks without floating pan and site-adapted by the design team. For tanks larger than 100,000 barrels (16,000,000 L), use the multicolumn API Std 650 design.

c) Field-erected tanks complying with DoD Standard Design AW 724-27. The standard design includes tanks ranging in capacity from 5,000 barrels (800,000 L) through 100,000 barrels (16,000,000 L) with internal pan and requires site-adapting by the design team. For tanks larger than 100,000 barrels (16,000,000 L), use the multicolumn API Std 650 design.

d) Require tanks to be inspected by a STI Registered Inspector with Level 1 and 2 Certification or an API Std 653 Certified Inspector, where applicable, prior to the tanks being put into service.

8.2 TANK ROOFS. For tanks with internal floating pans, design the roofs in conformance with DoD Standard Design AW 78-24-27.

8.3 INTERNAL FLOATING PANS.

a) Tanks containing Class I flammable fuels or mission-critical Class II combustible fuels, such as JP-8, shall be equipped with a full contact, aluminum honeycomb floating pan. Other Class II fuels require a floating pan if the tank does not comply with the spacing and diking requirements. Tanks storing mission-critical Class III fuels, such as JP-5 and diesel fuel marine (F-76), if located in hot (desert-like) climate, also require a floating pan to eliminate the fuel/air interface. \1\ The slotted well used for manual measurements shall be equipped with an approved floating plug. The 8 inch (200 mm) slotted stilling well for the automatic tank gauge system level sensing device and the 6-inch (150 mm) minimum nominal size slotted stilling well for the automatic tank gauge system water probe are allowed to be provided without floating plugs.

b) For cone roof tanks with floating pans, provide roof vent/inspection hatches in the fixed roof and overflow port/vents near the top of the shell near a device(s) in the floating pan which is (are) sized by the manufacturer to evacuate air and gases from underneath the pan when the pan is on its supports during filling operations.

c) Provide grounding bonds between the floating pan and shell as follows:

- Two /1/ lengths of bare, 3/16-inch (5 mm) diameter, stranded, extra-flexible, stainless steel wire rope, each extending from the top of the floating pan to the underside of the fixed roof.
- Attach two of the wires near the tank periphery, 180 degrees apart. Attach \1\ an additional third wire from the floating pan to the floating pan /1/ manhole cover.
- Securely connect the wires to the pan and extend vertically to the tank roof. Ensure wires are accessible for inspection.
- Ensure wires are long enough to accommodate the full travel of the pan. Locate wires to miss all interior tank appurtenances and structure.

d) Provide anti-rotation cables in accordance with applicable standards.

e) For cone roof tanks with floating pans, provide gauge and sampling hatches in accordance with applicable standards.

f) Provide a 36-inch (900 mm) diameter covered manhole in the floating pan.

8.4 TANK BOTTOMS. Slope the tank bottoms downward in accordance with applicable standards. A slope of 5 percent is required for positive drainage and self-cleaning action for tanks storing aviation turbine fuels. After tank construction is complete perform a hydrostatic test prior to tank coating. Conduct all tests as recommended by API Std 650.

8.5 FOUNDATIONS. Design tank foundations on the basis of a soils exploration program including preliminary exploration as a minimum and detailed exploration and testing, if existing soil data is not available and/or inadequate. Refer to UFC 3-220-10N. Analyze the results of the exploration program to determine the most practical and economical design to provide a stable foundation for the tank. As a minimum, use the following criteria for all tank designs:

a) Prevent external corrosion of tank bottoms by locating the tank bottom perimeters well above the general tank field grade, provide adequate tank field drainage away from the tank, and construct the foundation pad as specified in AW 724-27.

b) Ensure a minimum electrical resistance of 50,000 ohm-cm. Foundation material should be neutral or alkaline with a pH greater than 7, a chloride concentration less than 300 ppm, and a sulfate concentration less than 150 ppm as specified by applicable standards. The sand may be washed and the pH may be raised to meet the requirements. Include cathodic protection to prevent external corrosion of the tank bottoms. Do not use oil in the sand under the tank. Do not use dredge material or beach sand.

c) Provide good drainage under the tank.

- d) Provide a reinforced concrete ring wall foundation and secondary containment. Locate the top of the foundation a minimum of 12 inches (300 mm) above the dike basin.
- e) Cover the area beneath the tanks with a fuel-impermeable liner complying with applicable standards and meeting local and state requirements. Install all liners according to the manufacturer's requirements.

- f) Over the liner, provide a minimum of 12 inches (300 mm) of compacted clean sand or similar material as described above. Securely attach and seal the liner to the inside of the concrete foundation ring wall beneath the tank shell.

- g) Provide a leak detection system for the tank bottom by installing a pipe or pipes through the concrete foundation ring wall as a telltale for tank bottom leaks in accordance with applicable standards. These pipes will also permit water beneath the tank to escape by gravity.

- h) Perform subsurface investigation in sufficient detail to determine if any compressible, weak, organic, or otherwise objectionable soils exist within a distance of two tank diameters below ground surface.

- i) Estimate the magnitudes and rates of settlement (uniform, differential, and seismic induced) as part of the design. Provide adequate flexibility in piping, appurtenances, and other systems to accommodate anticipated settlements. Accomplish flexibility by using pipe offsets or ball joints. Do not use corrugated or bellows type expansion compensators.

- j) Where objectionable materials exist or magnitudes of anticipated settlement are sufficient to cause damage or unacceptable distortion, consider subsurface improvement. Potential improvement techniques may include removal of objectionable materials and replacement with clean compacted granular fill, preloading or surcharging in conjunction with drainage wicks, deep dynamic compaction, vibrocompaction, stone columns, compaction grouting, or similar techniques.

k) Where justified by subsurface conditions and economics, consider using deep foundations such as driven piling or drilled shafts.

9. UNDERGROUND HORIZONTAL STORAGE TANKS

9.1 GENERAL DESIGN CONSIDERATIONS. Where underground storage tanks of 50,000 gallon (191,000 L) or less capacity are required, use factory-built horizontal cylindrical double-wall tanks (welded steel or fiberglass reinforced plastic (FRP)). Ensure that contract requires the design and installation in accordance with 40 CFR Part 280 and NFPA 30 or any more stringent state or local criteria. Require separation of exterior tank walls from the interior walls with standoffs, thus creating an open space, or interstitial, for monitoring of leaks. This is called a Type II tank. Do not exceed 12 feet (3.7 m) in diameter for tanks. Limit tank length to eight times the diameter. Ensure that factory-fabricated tanks comply with UL 58 and STI P3 criteria.

9.2 INSTALLATION.

a) Install tanks in accordance with NFPA 30 and also in strict accordance with the manufacturer's installation instructions.

b) Install the tank so that the bottom slopes downward toward one end at a slope of 1 percent. Locate transfer pumps and suction piping at the low end of the tank.

c) Provide straps and anchors designed to prevent flotation of tanks located in areas with high groundwater levels or subject to flooding. Provide electrical isolation strips between hold-down straps and metal tanks. Anchors may be a concrete anchor slab under the tank or concrete deadmen.

d) Place tanks on a uniform bed of homogeneous granular material at least 12 inches (300 mm) thick. If a concrete anchor slab is used, place a minimum of 6 inches (150 mm) of bedding for steel tanks and 12 inches (300 mm) of bedding for fiberglass tanks between the tank and the concrete anchor slab. Do not use blocks, chocks, or rocks.

e) Ensure that tank is installed by state-certified contractor if state has a certification program.

f) Ensure that tank is installed by a contractor that is certified by the tank manufacturer.

10. UNDERGROUND VERTICAL STORAGE TANKS (CUT AND COVER)

10.1 GENERAL DESIGN CONSIDERATIONS. Underground vertical storage tanks are steel-lined reinforced concrete with leak monitoring capability. These tanks may be completely buried, surface-constructed and then covered with embankment, or any variation in between. Design underground vertical steel storage tanks in accordance with applicable standards, except as modified herein. These standards include tank sizes of 10,000 through 100,000 barrels (1,600,000 L through 16,000,000 L) capacity. In general, do not exceed 100,000 barrels (16,000,000 L) capacity. Alternative designs using prefabricated/pre-stressed tank sections must be approved by the Owner. Provide leak detection for underground storage tanks in accordance with federal, state, and local regulations.

11. APPURTENANCES. Table 2 describes appurtenances for atmospheric storage tanks and identifies the type of tank to which they should be mounted. Full seal weld all tank attachments to prevent moisture/water from corroding the tank shell and attachments.

12. HEATERS

12.1 GENERAL DESIGN CONSIDERATIONS. Provide tank heaters and controls for tanks intended for storage of high viscosity products, such as lube oils, or burner fuels No. 4, No. 5, and No. 6, in climates where the ambient tank temperature would be less than 20 degrees F (11 degrees C) above the fuel's pour point temperature. Heat heavy burner fuel oils and lube oils to a temperature of 20 degrees F (11 degrees C) above the fuel's pour point prior to pumping. Use one of the types of heaters listed below.

12.2 HEATING MEDIUM. Use the appropriate heating medium for the particular application based on temperature, pressure, and availability. Saturated steam is the preferred heating medium, but consider using hot oil, hot water, and electric heating where steam is not available from existing sources.

12.3 CONVECTION-TYPE. Use convection-type heaters installed inside a storage tank and capable of passing through a 36-inch (900 mm) diameter manhole with a capacity to raise the temperature of a full tank of burner fuel oil approximately 60 degrees F (33 degrees C) in 24 hours. The Owner will determine if the capacity of the heater could be reduced if it is not necessary to heat a full tank of fuel within 24 hours.

12.4 IN-LINE TYPE. In-line heaters consist of two general types: tank suction and straight tube. All in-line heaters are of the shell and tube construction. A tank suction or suction in-line heater is installed inside the tank on the tank issue line. The fuel oil enters the exchanger at the end within the tank and exits at the opposite end outside of the tank. The steam or other heating medium enters and exits the exchanger at the end outside of the tank. A straight tube or pipe in-line heater is installed directly into the pipeline. The fuel oil enters the exchanger at one end and exits from the other. The entry and exit points for the steam side can vary. The following criteria applies to in-line heaters:

- a) Capable of heating fuel oil passing through them from the ambient tank temperature to a minimum of 20 degrees F (11 degrees C) above the fuel oil's pour point temperature at required flow rate.

- b) If installed in tanks, allow removal of heater tube bundles without emptying the tank.

- c) If multipass in-line heaters are used, do not allow the oil temperature rise to exceed 30 degrees F (17 degrees C) per pass.

- d) Use carbon steel shells designed for a minimum 175 psig (1210 kPa) cold working pressure on both steam and oil sides.

- e) Do not exceed 0.2 psig (1.4 kPa) for the pressure drop on the oil side of pump suction line nor exceed 10 psig (70 kPa) of pressure drop for heaters installed on pump discharge.

12.5 INSULATION AND TRACING. In cases where fuels are heated, examine the possible economic incentives for insulating heated storage vessels and piping. In many cases, piping carrying heated products must be heat traced to prevent possible solidification of the fuel during a shutdown period. Insulate traced lines. Consider possible incentives for installing a condensate collection and return system. If a condensate return system is installed, include a monitor to detect oil in the condensate.

13. UNDERGROUND STORAGE TANK SPILL CONTAINMENT SYSTEMS

13.1 GENERAL DESIGN CONSIDERATIONS. Provide drainage structures to impound escaping fuel where rupture of an underground tank in a hillside location would endanger other activities and structures at elevations lower than the tank.

14. ABOVEGROUND TANK SPILL CONTAINMENT SYSTEMS

14.1 GENERAL DESIGN CONSIDERATIONS. Provide a spill containment system for all aboveground tanks to prevent spilled petroleum from leaving the property. Individual tanks larger than 10,000 barrels (1,600,000 L) in capacity should be enclosed in an individual diked enclosure. Groups of tanks, with no tank larger than 10,000 barrels (1,600,000 L) and not exceeding 15,000 barrels (2,400,000 L) in aggregate capacity, may be enclosed in a single diked enclosure. Subdivide each diked area containing two or more tanks by intermediate curbs to prevent spills from endangering adjacent tanks within the diked area. When subdividing is required, use intermediate curbs not less than 18 inches (450 mm) in height. Designer can take advantage of the exception granted for protected tanks by NFPA 30 or NFPA 30A if the provisions of that document are met and local, state, and federal regulations permit. Refer to DoD Standard Design AW 78-24-27. Use the following criteria for tank spill containment systems:

- a) The preferred method of containment is by diked enclosure (impounding spilled fuel around the tank by means of dikes) to prevent the accidental discharge of petroleum.

- b) As an alternative to diked enclosures, use a remote impoundment spill collection system consisting of a series of drains leading from storage tank areas to a remote containment or impoundment designed to prevent the accidental discharge of petroleum. This is not the preferred method and requires approval of The Owner. Generally, this system is used for tanks on a hillside.

- c) Slope the area within the containment at no less than 1 percent to carry drainage away from the tank to a sump located at the low point of the enclosure.
- d) Construct the drain line from the sump of petroleum-resistant, fire-resistant, impervious material. Do not use clay, concrete, fiberglass or plastic piping materials.
- e) Control drainage from the sump to the outside of the enclosure by an eccentric plug valve with indicator post located outside of the enclosure in an area that will be safely accessible during a fire.
- f) Do not allow fuel to run off or escape from the containment area under any circumstances. Provide means for disposing or for treating contaminated water from the containment to meet the most stringent of applicable federal, state, or local requirements.

14.2 SPILL CONTAINMENT SYSTEM CAPACITY

14.2.1 DIKED ENCLOSURES. Design diked enclosures in accordance with the most stringent of NFPA 30, 40 CFR Part 112, and other federal, state and local regulations. Additionally, ensure that the capacity of the diked enclosure is, at a minimum, greater than the largest tank volume located within the diked enclosure, plus sufficient freeboard equal to the greater of a 24-hour, 25-year storm or one foot (0.3 m) over the entire area of drainage \1\ or the flow of the water from firefighting activities /1/. In appropriate environmental climates, consider snow and ice accumulation as well. Limit dike heights to 6 feet (1.8 m) or less.

14.2.2 REMOTE IMPOUNDMENTS. If approved by the Owner, design remote impoundments in accordance with the most stringent of NFPA 30, 40 CFR Part 112, and other federal, state and local regulations. Additionally, ensure the capacity of the remote impoundment is, at a minimum, greater than the largest tank volume located within the area of drainage or the flow of water from firefighting activities on neighboring storage tanks sharing the same spill collection system /1/, plus sufficient freeboard equal to the

greater of a 24-hour, 25-year storm or one foot (0.3 m) over the entire area of drainage. When sizing the remote impoundment consider the total drainage area from all tanks that are included within the spill collection system. In appropriate environmental climates, consider snow and ice accumulation as well.

14.3 REMOTE CONTAINMENT/IMPOUNDMENT SPILL COLLECTION SYSTEMS.

Construct the remote impoundment as generally described for diked enclosures.

14.4 DIKED ENCLOSURE – EARTHEN DIKE TYPE. Construct earthen dikes of earthen materials with fuel impermeable liner cover. Where space is a premium, construct dikes of vertical concrete walls. For earthen dikes, make the minimum distance from the toe of the dike to the tank foundation 5 feet (1.5 m) and provide a flat surface on the top of the dike at least 3 feet (0.9 m) wide. Do not make earthen dike slopes steeper than 2.5 horizontal to 1 vertical. If space is restricted, dike slopes may be increased to 2 horizontal to 1 vertical if the sloped dikes are concrete surfaced. Cover the sides and top of the earthen dike and the floor around the tank with one of the following materials (see Facility Plate 019):

- a) A fuel impermeable liner. If liner is exposed, the exposed areas must be resistant to the effects of direct sunlight and to wind uplift. Provide sandbags in accordance with the appropriate UFGS, \1\ or other means approved by the liner manufacturer, /1/ to assure the liner is resistant to wind uplift. Follow the liner manufacturer's recommendations for protecting the liner by the use of geotextile cover or other recommended means. Provide a concrete maintenance pad for personnel access to the tank and for work areas around tank manholes and valves.
- b) Do not use Bentonite or a Bentonite composite material in the construction of dikes or basins.
- c) Do not use asphalt.

14.5 DIKED ENCLOSURE – REINFORCED CONCRETE DIKE TYPE. Design reinforced concrete (prefabricated or cast-in-place) dikes and their foundations to resist and contain the full hydrostatic load when filled to capacity. Consider the use of reinforced concrete blocks with or without exterior earth mounding. Use vertical reinforced concrete dikes where space is a premium. Seal all concrete surfaces with a flexible, UV-resistant, fuel-resistant coating if required by local or State regulations. Use a fuel impermeable liner as described above for the dike floor.

14.6 DIKED ENCLOSURE – COMBINATION DIKE TYPE. A vertical concrete wall backed by an external earthen berm may be used. Design the combined earthen and concrete unit and its foundation to resist and contain the full hydrostatic load when filled to capacity. Use a fuel impermeable liner as described above for the dike floor.

14.7 STORMWATER COLLECTION SYSTEMS. Design a stormwater collection system to contain, transport, treat, and discharge any stormwater that collects in the tank enclosure. Review state and local regulations for design requirements and permitting of stormwater treatment systems.

14.8 DIKE ACCESS. Provide concrete, steel, or aluminum steps with pipe handrails for passage across a dike. Steps and handrails must comply with 29 CFR Part 1910.36. Include a removable section of the handrail to provide access to the flat top of earthen dikes. If steel steps are used, they should be hot-dipped galvanized after fabrication. Provide enough access locations for safe emergency egress and for normal operation. This will normally include steps over the dikes separating adjacent tanks, as well as on one wall without an adjacent tank. Locate steps at the most accessible points, preferably on the same side as the access stairs to a tank roof. For tanks \1\ /1/ 10,000 barrels (1,600,000 L) and larger, consider providing earth-filled ramps to permit vehicle access into the dike when approved by The Owner. If there is sufficient need to provide vehicle access into diked areas, provide a concrete paved road and/or earth-filled ramp for vehicle travel-ways. A removable steel bulkhead section may be a cost-effective method to provide access for dikes with vertical reinforced concrete walls. Where the vehicle

access road crosses the dike, provide a security gate and prominent sign indicating that access is limited to a 1-ton pick-up truck that is compliant with NFPA 70 Class I, Group D, Division 2 criteria.

15. MISCELLANEOUS USE TANKS. This paragraph provides design guidance for miscellaneous use tanks. These tanks are typically less than 550 gallons (2,100 L) in capacity. Check state and local regulations before beginning design. If a miscellaneous use tank has a capacity greater than 12,000 gallons (45,800 L), follow the requirements of Table 2. Otherwise, use the standards described below.

15.1 INSTALLATION. Install the tank in conformance with the requirements of NFPA 30. The exception used for the deletion of dike containment is acceptable if all of the criteria associated with that exception are met. Provide containment for all tanks, regardless of size, except small residential heating oil tanks, by complying with the paragraph titled “Aboveground Tank Spill Containment Systems” in this chapter of this UFC or by using properly installed aboveground concrete-encased tanks in accordance with the paragraph titled “Horizontal Aboveground Tanks (Protected Tanks)”.

15.2 HEATING OIL TANKS. Comply with NFPA 31.

15.3 GENERATOR FUEL TANKS. Comply with NFPA 31, NFPA 37, and NFPA 110.

15.4 FIRE PUMP FUEL TANKS. Comply with NFPA 20, NFPA 30, and NFPA 31.

15.5 WASTE OIL TANKS. Check local and state environmental regulations for any additional requirements for storage of waste oil.

15.6 CONTAINMENT. As discussed previously in this chapter, provide containment, under and around all aboveground tanks except home heating oil tanks.

15.7 UNDERGROUND TANKS. Ensure all underground tanks are double-walled and have overfill protection, as described previously.

16. SHIPBOARD OFF-LOAD FUEL STORAGE TANKS

16.1 FUNCTION. In addition to regular storage, consider a storage tank for fuel removed from ships that may be off-specification or otherwise not satisfactory for its intended use. This fuel may be downgraded to heating oil or diesel fuel marine.

16.2 GENERAL DESIGN CONSIDERATIONS. Determine the volume requirements of the contaminated fuel storage tank by an activity survey. Provide bottom-loading facilities for tank truck loading and off-loading of contaminated fuel.

16.3 LOCATIONS. Locate the contaminated fuel storage tank(s) in or near the facility tank farm. Clearly mark the tank(s) as to the type or grade of fuel.

17. JET ENGINE TEST CELL FUEL STORAGE TANKS. Design jet engine test cell fuel storage and issue systems to the same standards as operating storage tank fuel systems (e.g., high level alarms, gauging, shut-offs, etc.). Normally, tanks are refilled using station aircraft refueling trucks through aircraft single-point refueling adaptors.

Item	Appurtenance	V-A	H-A	H-U	F-A	P-A	V-U
Manhole							
a	A 30-inch (750 mm) diameter manhole, a minimum of one manhole for tanks between 1,000 gallons (4,000 L) and 5,000 gallons (19,000 L) capacity, and a minimum of two manholes (both are to be at least 36 inches (900 mm), for tanks larger than 5,000 gallons (19,000 L) capacity.		✓	✓	✓	✓	✓
b	A dedicated manhole, other than required above, as the primary point for piping penetrations into a tank (may be as small as 22 inches (559 mm)).			✓			
c	A \1\ shell /1/ manhole located above the internal floating pan's high position to aid in venting the tank during cleaning and to provide access to the floating pan's elastomeric wiper seals as required by DoD Standard <u>AW 78-24-27</u> .	✓					
d	Containment sumps and extension manhole.			✓			
e	Roof manholes in accordance with <u>API Std 650</u> . \1\ /1/ Locate the roof manholes near the perimeter of the roof at opposite ends of a diameter and approximately 90 degrees from the shell manholes.	✓					
f	Shell manholes in accordance with <u>API Std 650</u> . Two 36-inch (900 mm) shell manholes 180 degrees from each other. Align shell manholes parallel with prevailing wind direction. \1\ Support shell manhole covers by davits /1/.	✓					
g	A bolted cover in the roof for installation and removal of the internal floating pan as required by the tank supplier based on the pan manufacturer.	✓					
\1\ Inspection Hatches /1/							
h	\1\ A minimum of four 24-inch (600 mm) square inspection hatches on fixed roof tanks with floating pans. Inspection hatches are not required for tanks without floating pans. /1/	✓					
Ladder/Stairs							
i	Internal ladders (in accordance with OSHA criteria) for tanks of 5,000 gallons (19,000 L) or larger. \1* with floating pans /1/	✓	✓	✓	✓	✓	✓
j	An external ladder and platform with safety railing for gauging and sampling in accordance with <u>29 CFR Part 1910.23</u> (if height justifies it).		✓		✓	✓	
k	Ladders, railings, toeboards, a spiral stairway, top platform, and handrail in accordance with <u>API Std 650</u> and OSHA requirements. Provide stairways to access high level shut-off and alarms. Provide \1\ metal bar grating stair tread and platforms. Provide stair tread with non-slip nosings /1/.	✓					

Table 2

Appurtenances

V-A = Vertical Aboveground Storage Tank H-A = Horizontal Aboveground Storage Tank
 H-U = Horizontal Underground Storage Tank F-A = Fire-Resistant Aboveground Storage Tank
 P-A = Protected Aboveground Storage Tank V-U = Vertical Underground Storage Tank

Item	Appurtenance	V-A	H-A	H-U	F-A	P-A	V-U
Level Alarms							
I	<p>1. Tanks Greater \geq 30,000 gallons (112 500L):</p> <p>An individual automatic level alarm system, independent of the gauging device or system for each tank. Include high, high-high, low and low-low level alarms. On aboveground tanks: provide a means to manually test each alarm sensor to ensure system operability without a full tank; locate level alarm equipment for ready access from ground level, stairway platforms, or roof access. On aboveground vertical tanks set level alarms as defined in <u>AW 78-24-27</u>. For underground tanks, high and high-high will be 90 and 95 percent, respectively (although this may have to be adjusted downwards for horizontal tanks). On tanks without floating pans, set the low level alarm no less than 5 percent before loss of suction to avoid pump cavitation, and the low-low level alarm as defined in <u>AW 78-24-27</u>. In determining the low level, consider the time it would take for the pump or system to shut down. Provide both audible and visible alarms in a manned area responsive to the alarm. Review facility size and operating method to determine the most desirable location for audible and visible alarms, this will usually be in the tank farm or near the operations building. Interface the alarm output to stop issue pump on low level alarm and receipt pump/valve on high-high level alarm. Install alarms on winter sun side of the tank. Comply with most stringent of federal, state, or local regulations. For vertical aboveground tanks, see <u>Facility Plates 014 and 015</u>.</p>	✓ *	✓ *	✓ *	✓	✓	✓

Table 2 (continued)
Appurtenances

Item	Appurtenance	V-A	H-A	H-U	F-A	P-A	V-U
I (cont)	<p>2. Tanks < 30,000 gallons (112,500 L):</p> <p>An automatic level alarm system for each tank to include high, high-high, low and low-low level alarms. On aboveground tanks: provide a single multi-set point Automatic Tank Gauge (ATG) level probe with continual/dynamic testing for both gauging and alarm; locate ATG level alarm equipment for ready access from roof or platform access. Additional redundancy level sensors or switches that interface with the ATG may be added. On aboveground vertical tanks, in general conformance with <u>API RP 2350</u>, set high-level at 95 percent and high-high at 98 percent; on tanks with floating pans locate the low level at 5 percent and locate the low-low level alarm at 2 percent above the low level of the floating pan. For underground tanks, high and high-high will be 90 and 95 percent, respectively (although this may have to be adjusted downwards for horizontal tanks). On all tanks without floating pans, set the low level alarm 5 percent before loss of suction, and the low-low level alarm 2 percent before loss of suction to avoid pump cavitation. In determining the low level, consider the time it would take for the pump or system to shut down. Provide both audible and visible alarms in a manned area responsive to the alarm. Review facility size and operating method to determine the most desirable location for audible and visible alarms, this will usually be in the tank farm and in or near the operations building. Interface the alarm output to stop issue pump on \1\ low-low /1/ level alarm and receipt pump/valve on high-high level alarm. Comply with most stringent of federal, state, or local regulations. For vertical aboveground tanks, see <u>Facility Plates 014 and 015</u>.</p>	<p>✓ *</p>	<p>✓ *</p>	<p>✓ *</p>	<p>✓</p>	<p>✓</p>	<p>✓</p>

Table 2 (continued)
Appurtenances

Item	Appurtenance	V-A	H-A	H-U	F-A	P-A	V-U
I (cont)	<p>3. Product Recovery Tanks (PRT):</p> <p>An automatic level alarm system for each tank to include high and high-high level alarms. On aboveground tanks: provide a single multi-set point Automatic Tank Gauge (ATG) level probe with continual/dynamic testing for both gauging and alarm; locate ATG level alarm equipment for ready access from ground level or stairway platforms. Additional redundancy level sensors or switches that interface with the ATG may be added. On aboveground tanks, in general conformance with <u>API RP 2350</u>, set high-level at 95 percent and high-high at 98 percent. For underground tanks, high and high-high will be 90 and 95 percent, respectively (although this may have to be adjusted downwards for horizontal tanks). Provide both audible and visible alarms in a manned area responsive to the alarm. Review facility size and operating method to determine the most desirable location for audible and visible alarms, this will usually be in the tank farm and in or near the operations building. Interface the alarm output to receipt pump/valve on high-high level alarm. Comply with most stringent of federal, state, or local regulations. For vertical aboveground tanks, see <u>Facility Plates 014</u> and <u>015</u>.</p> <p>/1/</p>	✓ *	✓ *	✓ *	✓	✓	✓
<p>*NOTE: State and local regulations may be more restrictive. Because underground and aboveground horizontal tanks will fill extremely fast in the last 5 percent, values of high level alarm positions should be chosen based on filling rate, tank size, and time needed to respond to the alarm condition. Adjust values as well for extremely large vertical tanks with small receipt rates and extremely small vertical tanks with high receipt rates.</p>							

Table 2 (continued)
Appurtenances

Item	Appurtenance	V-A	H-A	H-U	F-A	P-A	V-U
Vents							
m	Open atmospheric vents with weather hoods and bird screens for tanks to be used for products with <u>true vapor pressure</u> of 0.75 psia (5 kPa) or less. For higher <u>vapor pressure</u> , or if a vapor recovery system is used, provide pressure/vacuum vents in lieu of open vents. Consider using pressure/vacuum vents if product quality is at risk by blowing sand, dust, or snow. Comply with NFPA 30, host nation requirements, <u>Chapter 2</u> of this UFC, API Std 650, API Std 2000, 29 CFR Part 1910.106, and DoD Standard Design AW 78-24-27, where applicable. Do not use flame arrestors.	✓	✓	✓	✓	✓	✓
n	Emergency relief venting with capacity in accordance with NFPA 30 and UL 142, as applicable. For vertical aboveground tanks, a 11\ floating roof or weak 11/ roof-to-shell seam, as specified in API Std 650, may be used to fulfill emergency relief requirements.	✓	✓		✓	✓	✓
Gauge/Gauge Hatch/Stilling Wells							
o	A liquid level gauge calibrated in 1/16-inch (2 mm) graduations mounted at 60 inches (1500 mm) above the walking surface.	✓	✓	✓	✓	✓	✓
p	11\ Automatic Tank Gauging (ATG) for all tanks with fuel managed through the Defense Logistics Agency's Business Modernization (BSM Enterprise Resource Programs (ERP) - Fuels section), that complies with API MPMS Chapter 3. Key features include: measures fluid level to ±0.05 inch (1 mm); measures standard volume ±0.1 percent; measures average product temperature ±1 F (0.5 C); measures product density ±1 percent; detects water in the tank sump to a level equal to or slightly above the water draw-off pipe; converts volume to API standard conditions; local tank readout; For tanks that are 30K gallons or less certain ATG systems (Veeder-Root and Ronan) can provide backup alarms for high, high-high, low, and low-low level conditions; meet American Standard Code for Information Interchange (ASCII) interface. 11/	✓	✓	✓	✓	✓	✓
q	A 4-inch (100 mm) gauge hatch with drop tube to within 3 inches (75 mm) of the bottom of the tank. A second 4-inch (100 mm) opening without a drop tube or gauge hatch.		✓	✓			✓
* = Lowest point in the tank not the sump.							
r	11\ One 10-inch (250 mm) roof flanged nozzle with an 8-inch (200 mm) aluminum, fully slotted, stilling	✓					✓

Table 2 (continued)
Appurtenances

Item	Appurtenance	V-A	H-A	H-U	F-A	P-A	V-U
	well for ATG near the edge of the roof near the top of the stairway platform. /1/						
s	\1\ One 8-inch (200 mm) roof flanged nozzle with a 6-inch (150 mm) aluminum, fully slotted, stilling well for temperature and water bottom sensor, as close to or in the tank sump as possible. See DoD Standard Design AW 78-24-27. /1/	✓					✓
t	\1\ One 10-inch (250 mm) roof nozzle and an /1/ aluminum, slotted stilling well extended to within 3 inches (75 mm) of the bottom of the tank for gauging and sampling. A datum plate to establish a gauging zero point.	✓					✓
Piping Connection							
u	Inlet fill connection. See Facility Plates 016, 017, and 018, as applicable. For H-A tanks, Facility Plate 017 applies to single wall tanks only.	✓	✓	✓			
v	Main suction and low suction. See DoD Standard Design AW 78-24-27.	✓					
w	Inlet fill pipe with horizontal exit perpendicular to a tank radial. Discharge is approximately 4 inches (100 mm) above tank floor and enlarged to reduce fuel velocity. An inverted trap is placed in the line to serve as a liquid lock to prevent entry of fire or an explosion from outside the fill pipe.						✓
Overfill Protection							
x	Overfill protection with a hydraulically operated diaphragm control valve. Tanks connected to commercial pipelines or marine offload systems with restrictions on shut-off may require diversion to additional tankage. On vertical tanks, valve typically closes midway between high and high-high levels, but ensure valve closes no later than on high-high level. For underground tanks, (per NFPA 30) and in aboveground horizontal tanks, automatically shut off the flow into the tank when the tank is no more than 95 percent full. Comply with most stringent of federal, state, or local regulations. \1\ Include /1/ a solenoid on the control valve to close the valve as a backup. Use API RP 2350 to establish the proper overfill level setting. On gravity drop fills, replace valve with an integral high level shut-off valve in the drop tube. Prior to designing automatic valve closure features, conduct a surge analysis on pressure filled systems. See Plates 017 and 018. * If pressure-filled.	✓	✓	✓ *	✓	✓	✓
y	A lockable, welded steel overfill protection box (15 gallon (60L) minimum) and a manual drain valve to				✓	✓	

Table 2 (continued)
Appurtenances

Item	Appurtenance	V-A	H-A	H-U	F-A	P-A	V-U
	return spills to the inner tank (omit the drain feature on aviation turbine fuel tanks).						
Water Drawoff							
z	A 2-inch (50 mm) <u>double block and bleed</u> , plug valve \1\1/ at the low end of the tank, unless tank contains aviation turbine fuels with icing inhibitors. In those cases, the <u>water drawoff</u> valve may be a ball valve.		✓				
aa	<u>Water drawoff</u> connections. See <u>DoD Standard Design AW 78-24-27</u> .	✓					
bb	A 1-inch (25 mm) connection from the low end of the tank to approximately 3.5 feet (1.1 m) above the ground and equipped with a positive displacement-type, hand-operated pump for <u>water drawoff</u> . For Air Force projects, use electrical pumps only.			✓			
cc	A water removal suction tube at low end of tank with connection for water removal by truck. Consider installing a fixed, hand-operated pump as an alternative.				✓	✓	
dd	A central <u>sump pump</u> .						✓
Ball Joints							
ee	Ball joints on pipes to relieve strain caused by tank settling or seismic activity. Ensure that contract specifications do not allow piping connections to be made until after the tank has been completely tested and allowed to settle. As an alternative, settlement calculations can be made and piping flexibility can be designed to account for settling. In this case, pipe can be connected prior to testing. * May be required on tanks 25,000 gallons (94,600 L) and larger.	✓	✓ *				
Cable Supports							
ff	On the fixed roof of all tanks, provide two scaffold cable supports in accordance with <u>API Std 650</u> . Locate the supports near the center of the tank so that supported cables will have maximum range and flexibility of operation with minimum interference with other tank fittings.	✓					
Striker Plates							
gg	Striker plates under all openings used for manual gauging in steel tanks and all openings in fiberglass tanks.	✓	✓	✓	✓	✓	✓
Monitoring Port							
hh	A 2-inch (50 mm) monitoring port including a tube which provides a means to detect product leakage from the primary tank into the secondary tank.				✓	✓	

Table 2 (continued)
Appurtenances

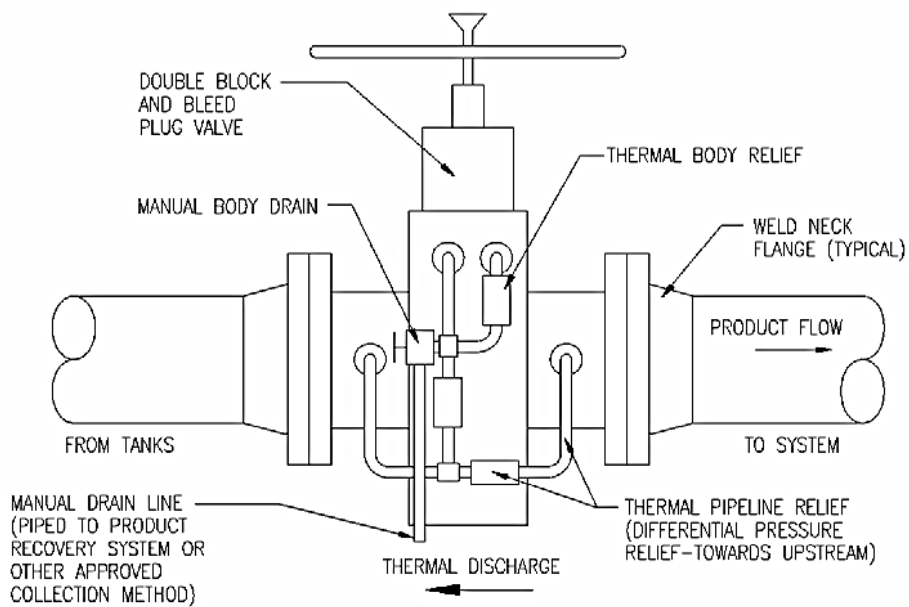

INTEGRAL VALVE THERMAL RELIEF PIPING SYSTEM

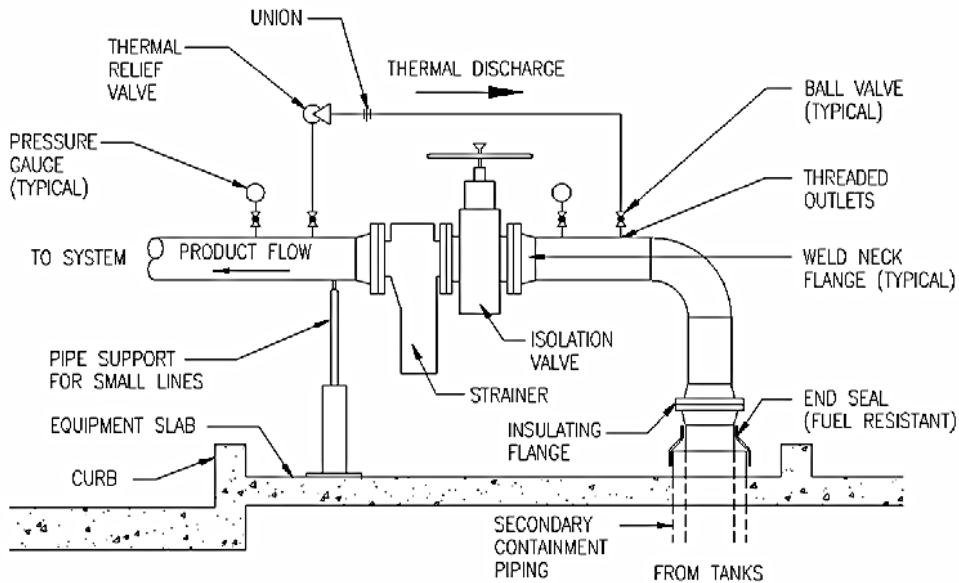

CONVENTIONAL THERMAL RELIEF PIPING SYSTEM

NOT TO SCALE

<p>TITLE Thermal Relief Piping Systems Integral Valve And Conventional</p>	<p>DATE 07/08</p>	<p>FACILITY PLATE 023</p>
--	-----------------------	-------------------------------

Figure 1

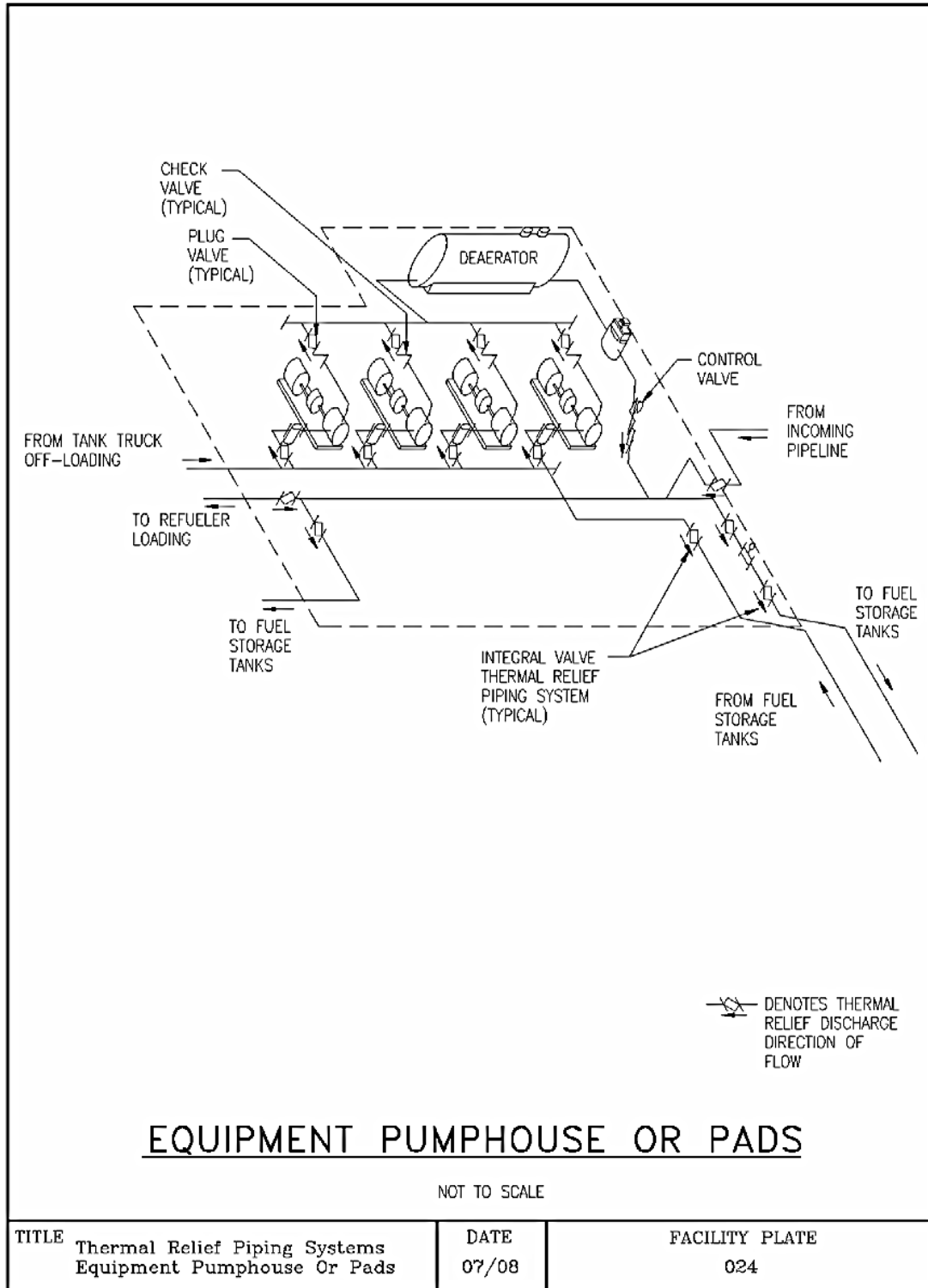

Figure 2

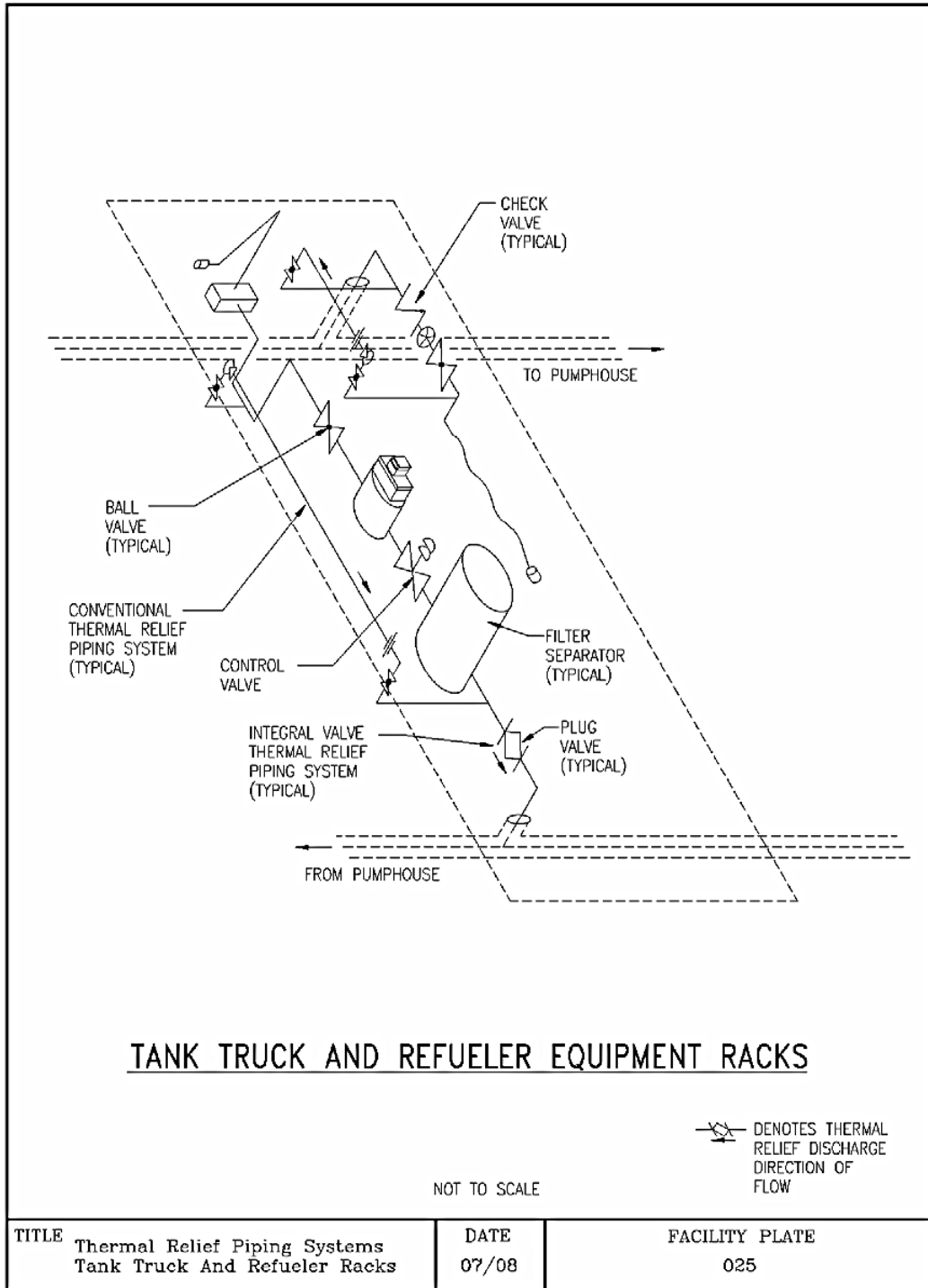

Figure 3

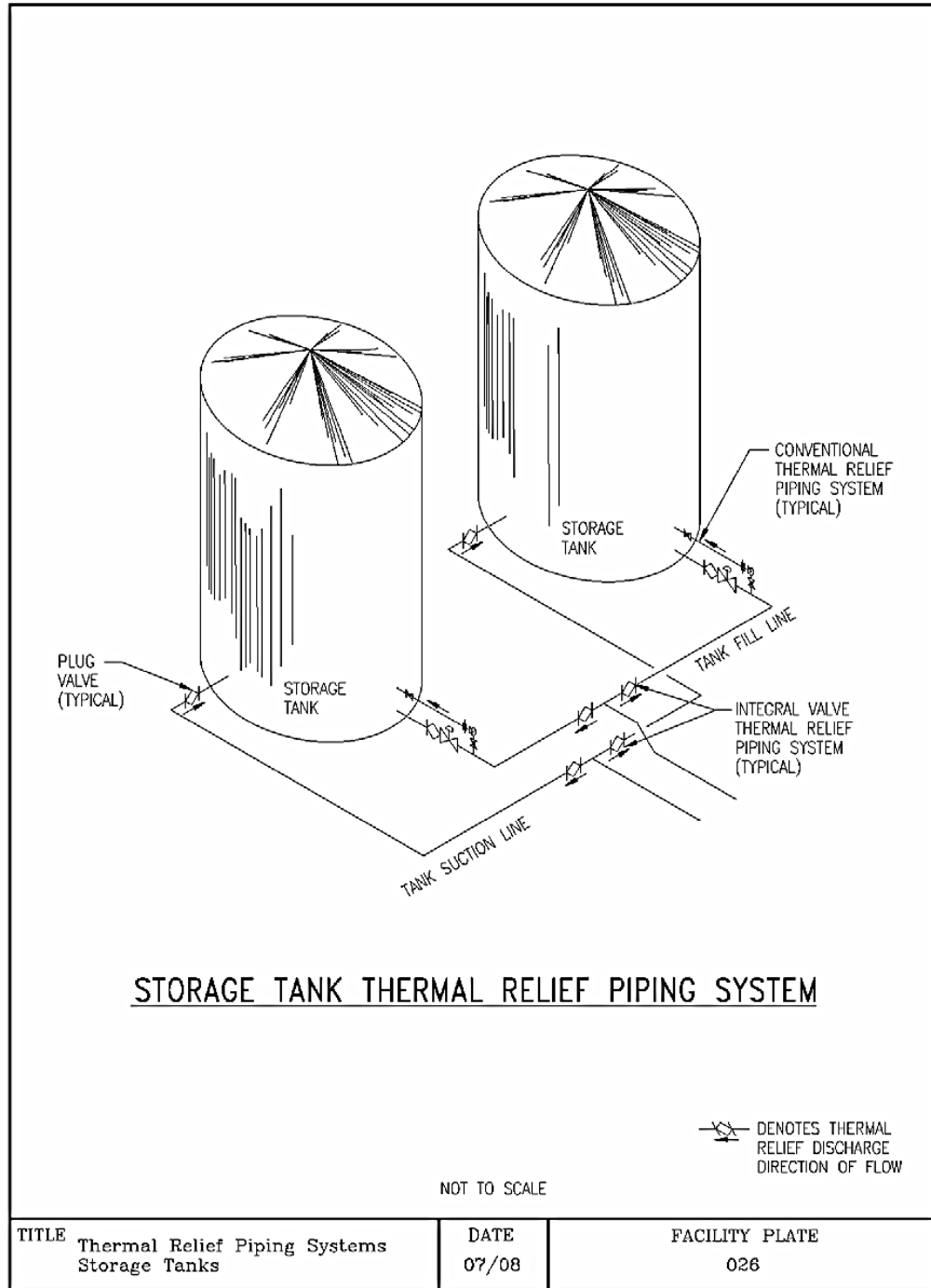

Figure 4

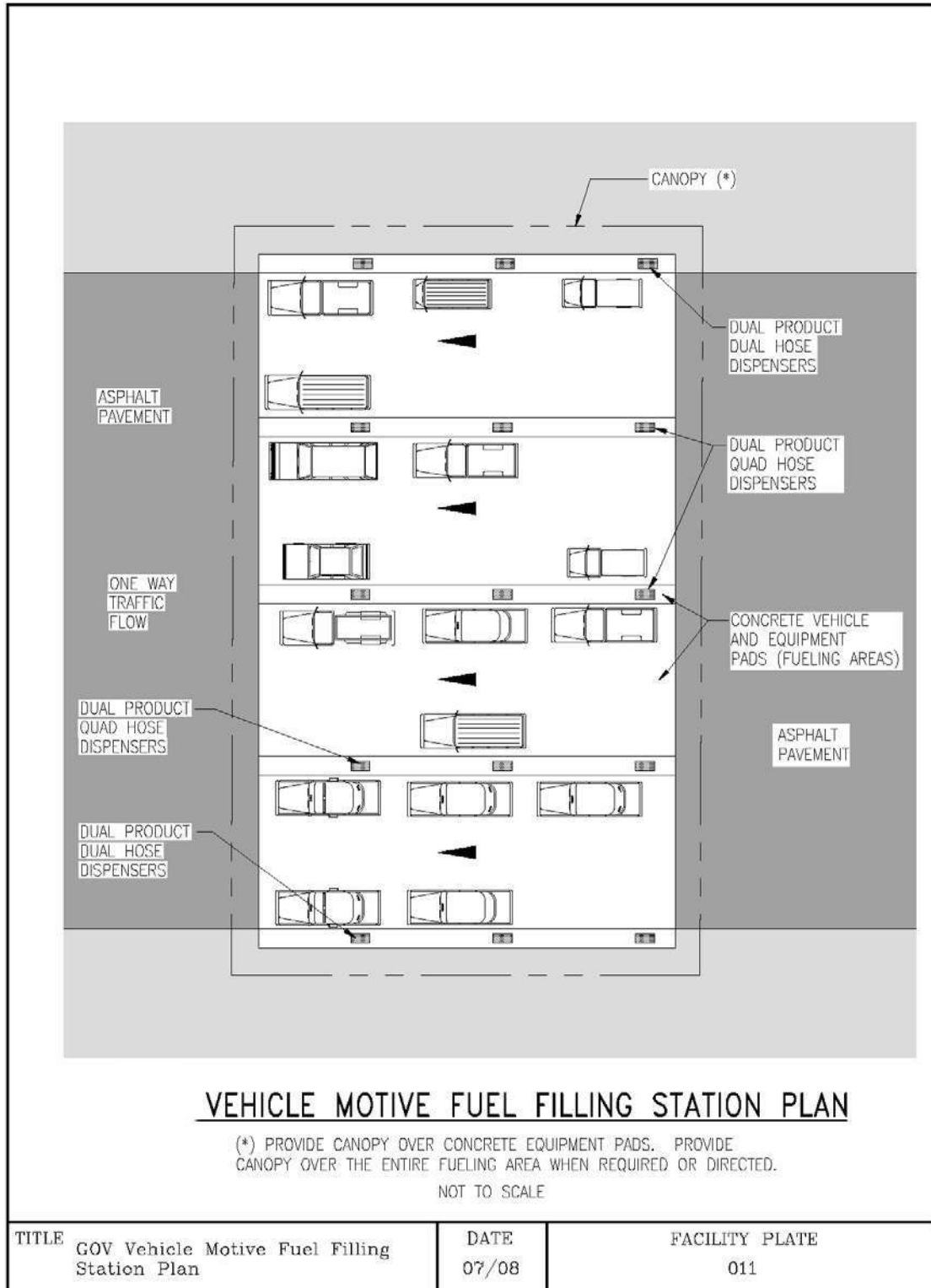
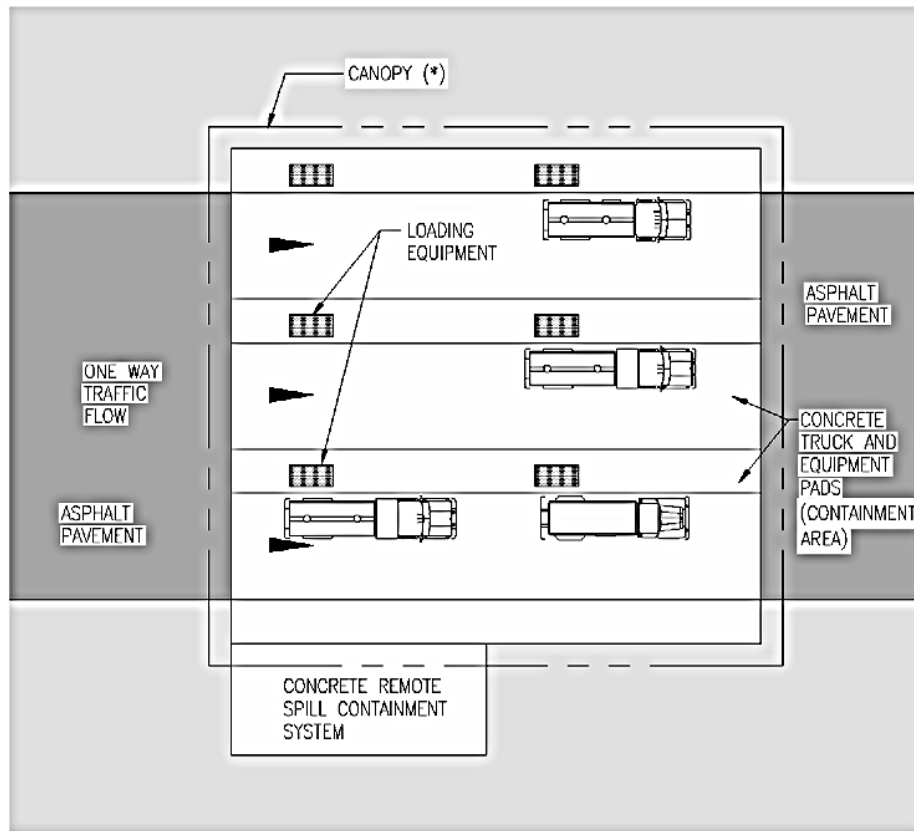

Figure 5



REFUELER GROUND PRODUCT TRUCK LOADING FACILITY PLAN

(*). PROVIDE CANOPY OVER CONCRETE EQUIPMENT PAD. PROVIDE CANOPY OVER THE ENTIRE CONTAINMENT AREA WHEN REQUIRED OR DIRECTED.

NOT TO SCALE

TITLE Refueler Ground Product Truck Loading Facility Plan	DATE 07/08	FACILITY PLATE 012
--	----------------------	------------------------------

Figure 6

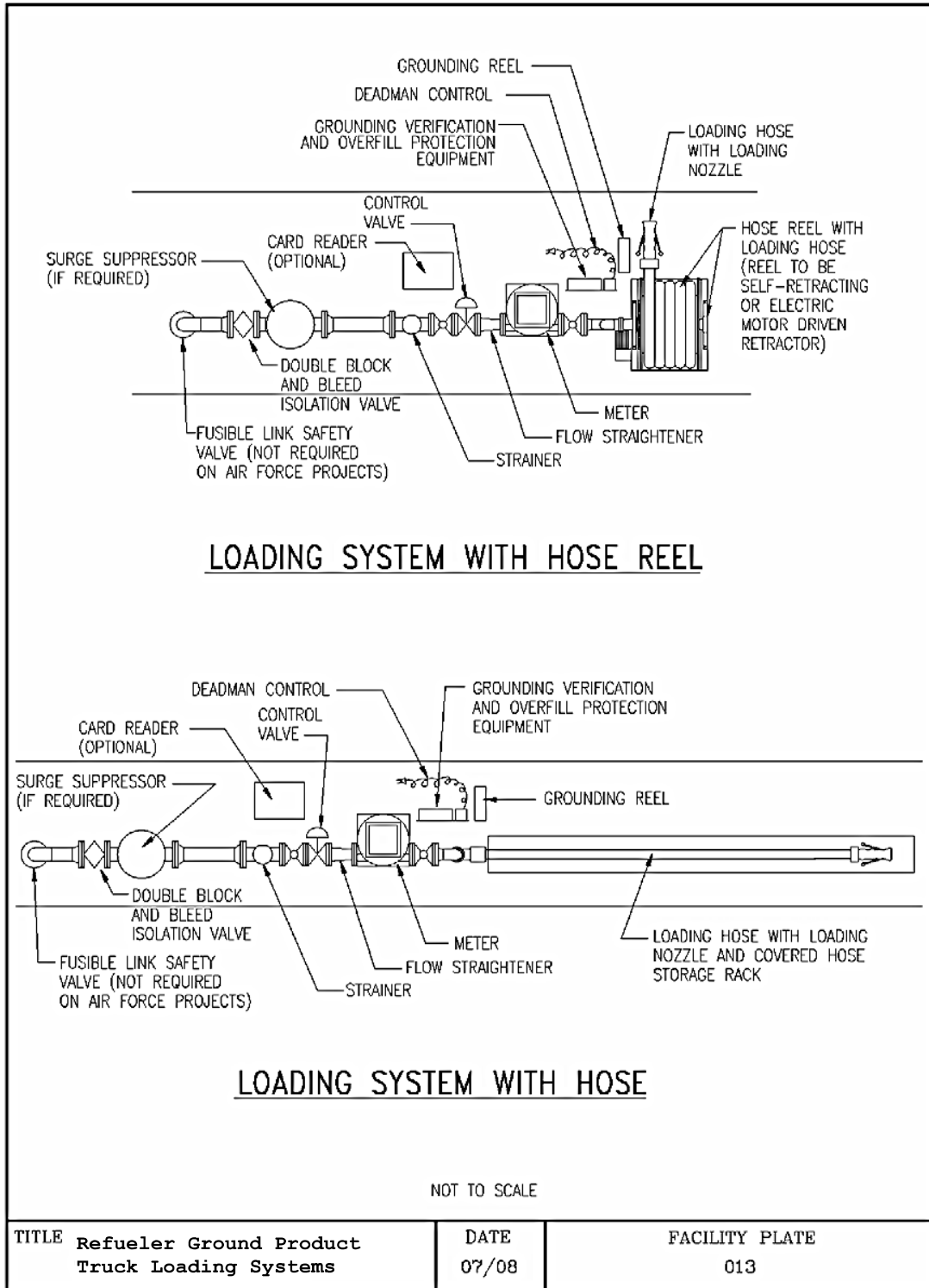

Figure 7

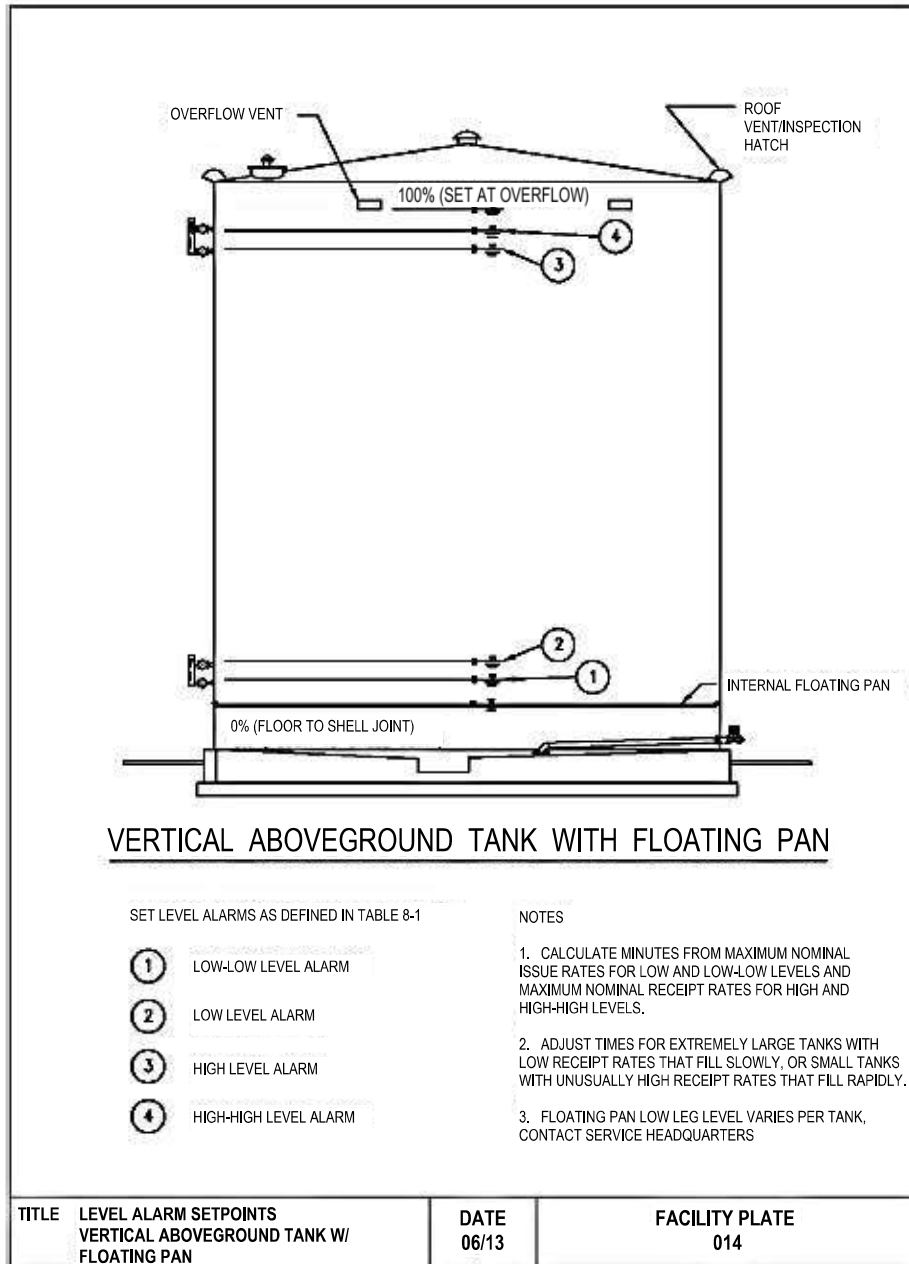

Figure 8

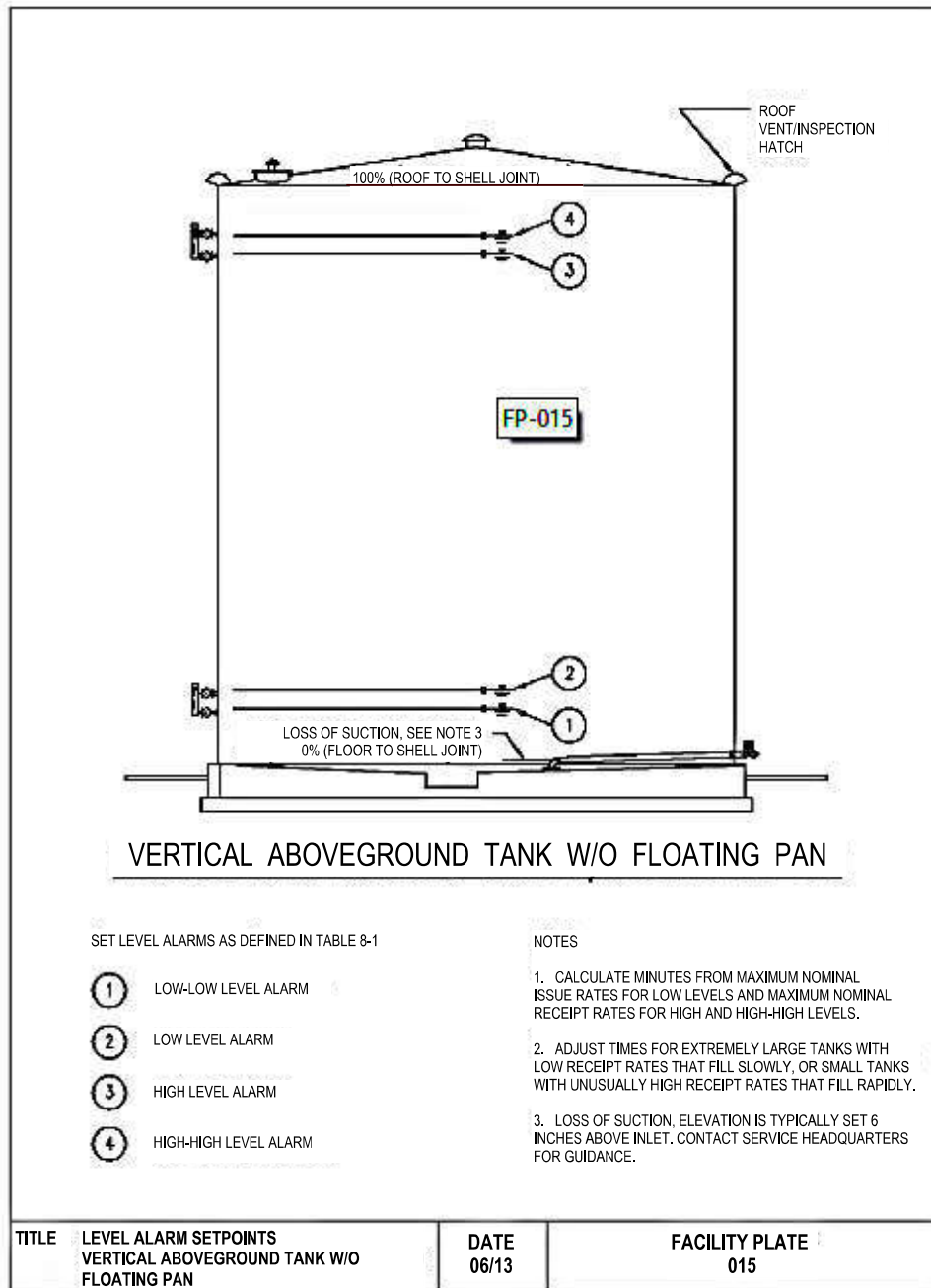

Figure 9

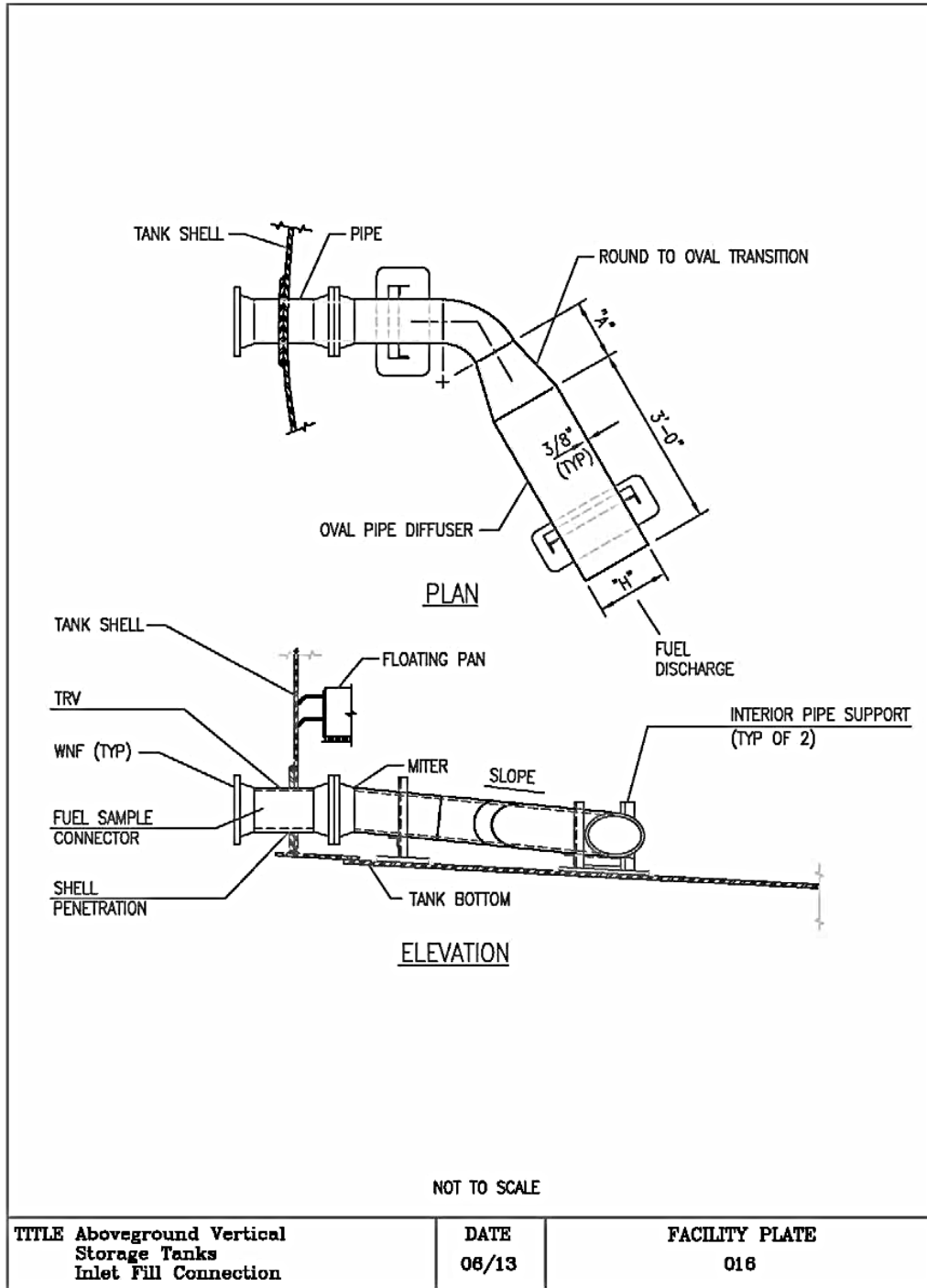
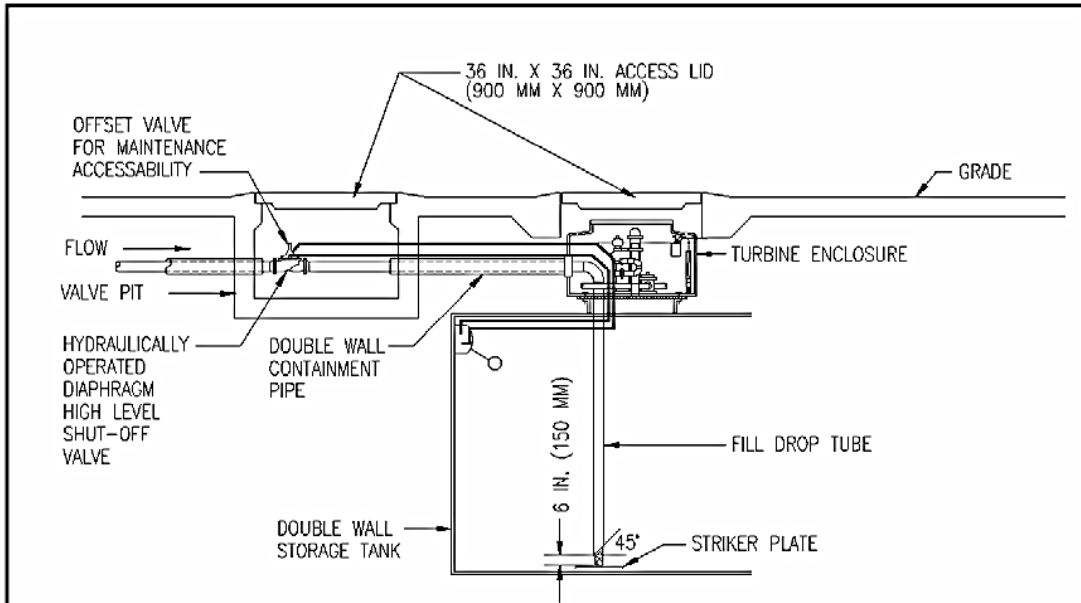
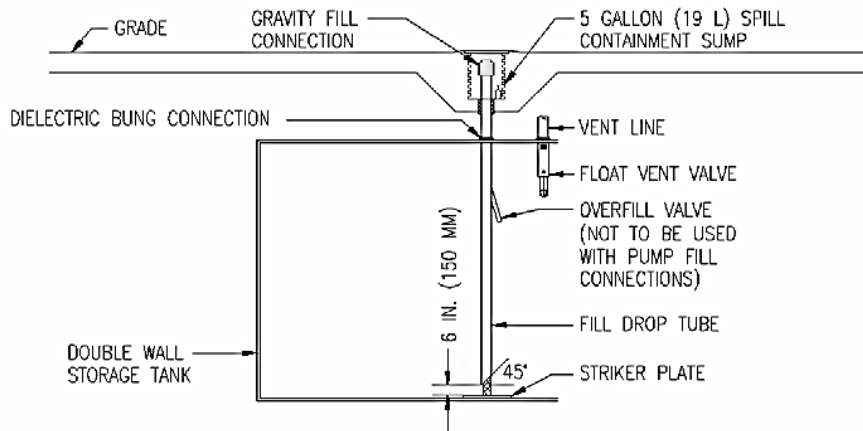

Figure 10



HORIZONTAL UNDERGROUND PUMPED FILL CONNECTION



HORIZONTAL UNDERGROUND GRAVITY DROP FILL CONNECTION

NOT TO SCALE

TITLE	Horizontal Underground Storage Tanks Inlet Fill Connection	DATE	07/08	FACILITY PLATE	017
-------	--	------	-------	----------------	-----

Figure 11

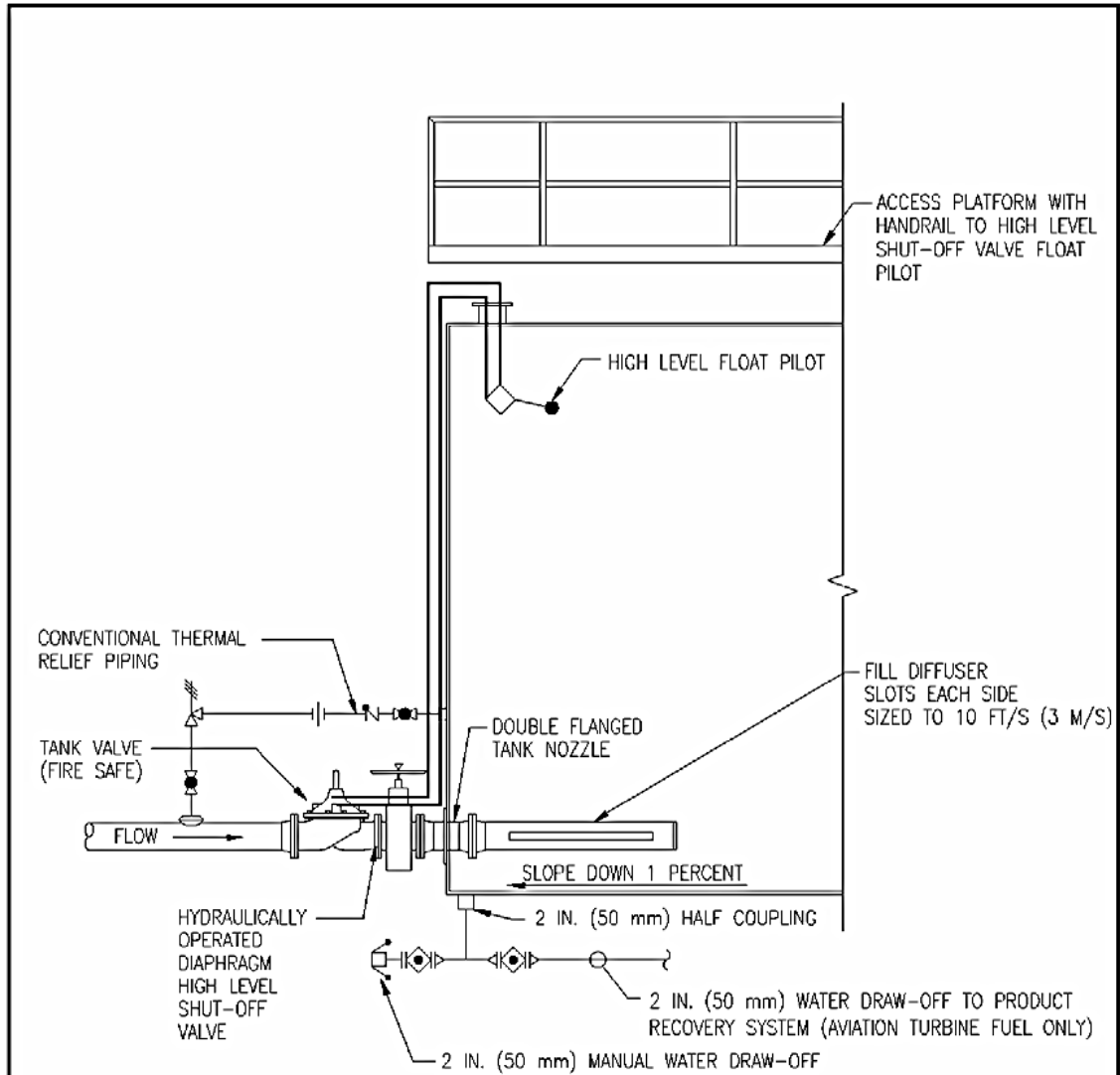

HORIZONTAL ABOVEGROUND PUMPED FILL CONNECTION

NOTES:

1. FACILITY PLATE APPLIES ONLY TO HORIZONTAL, SINGLE WALL ABOVEGROUND, TANKS AS DEFINED BY NFPA 30 AND NFPA 30A.
2. WATER DRAW-OFF LINE SIZE IS A MINIMUM.
3. LIMIT FILL RATE TO 3 FT/S (900 mm/S) UNTIL THE FILL DIFFUSER IS COMPLETELY SUBMERGED.

NOT TO SCALE

TITLE	Horizontal Aboveground Storage Tanks Inlet Fill Connection	DATE	07/08	FACILITY PLATE	018
-------	--	------	-------	----------------	-----

Figure 12